

	5		4		3		2		1
PART NUMBER	ITEM ① BODY	ITEM ② CONTACT	ITEM ③ INSULATOR	ITEM ④ NUT					
25-7510	BRASS NICKEL PLATED	BRASS GOLD PLATED	DELTRIN	ZINC NICKEL PLATED					

DRAWING NO.
25-7510

REVISIONS	
A	RELEASE FOR QUOTATION
	03-28-06 Y U W T
B	ADD NOTE 4&5
	11-15-06 Y U W T

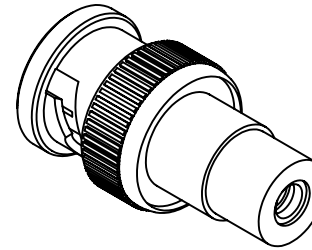
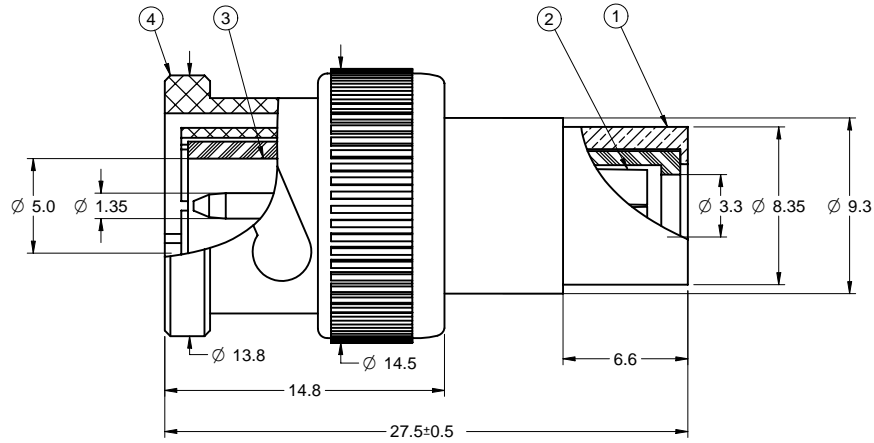
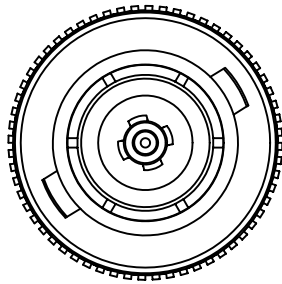

NOTES:

- ELECTRICAL SPECIFICATIONS
 IMPEDANCE: 50 OHMS NOMINAL
 FREQUENCY RANGE: 0-4 GHz
 WORKING VOLTAGE: 500 Vrms MAX AT SEA LEVEL
 DIELECTRIC WITHSTANDING VOLTAGE: 1500 vrms AT SEA LEVEL
 CORONA LEVEL: 375 VOLTS MINIMUM AT 70,000 FEET
 CONTACT RESISTANCE: OUTER-0.2 MILLIOHMS MAXIMUM
 CENTER-2.1 MILLIOHMS MAXIMUM
 INSULATION RESISTANCE: 5000 MEGOHMS MINIMUM
- MECHANICAL SPECIFICATIONS
 DURABILITY: 500 CYCLES MIN
- ENVIRONMENTAL SPECIFICATIONS
 RECOMMENDED TEMPERATURE RANGE: -55 °C TO +85°C
 MOISTURE RESISTANCE: MIL-STD-202
- PRODUCT SHOULD BE RoHS COMPLIANCE
- PACKAGING REQUIREMENT FOLLOWS ENGINEERING DOCUMENT P/N 836-40200001XX

THIS DRAWING TO BE INTERPRETED
PER ANSI Y 14.5M - 1994

COMPANY CONFIDENTIAL

TOLERANCE UNLESS OTHERWISE SPECIFIED		DRAWN BY BETTY.YU	DATE 11-14-06
DECIMALS	mm	CHECKED BY IVON.W	DATE 11-14-06
X	± 0.5	APPROVED BY THOMAS	DATE 11-14-06
X.X	+ 0.2		
X.XX	+ 0.1		
ANGLES	+ 0.5°	U/M	mm

	Connectivity Solutions	
	TITLE ADAPTER RCA JACK TO BNC PLUG	

THIS DRAWING WAS PRODUCED BY COMPUTER, DO NOT SCALE DRAWING OR UPDATE MANUALLY.		SHEET 1 OF 1	DRAWING NO. 25-7510	SIZE C
---------------------------------------------------------------------------------	--	-----------------	------------------------	-----------