

EiceDRIVER™

1ED020I12-BT

Single IGBT Driver IC

Final Data Sheet

Rev 2.0, 2012-07-31

Industrial Power Control

**Edition 2012-07-31**

**Published by  
Infineon Technologies AG  
81726 Munich, Germany**

**© 2012 Infineon Technologies AG  
All Rights Reserved.**

### **Legal Disclaimer**

The information given in this document shall in no event be regarded as a guarantee of conditions or characteristics. With respect to any examples or hints given herein, any typical values stated herein and/or any information regarding the application of the device, Infineon Technologies hereby disclaims any and all warranties and liabilities of any kind, including without limitation, warranties of non-infringement of intellectual property rights of any third party.

### **Information**

For further information on technology, delivery terms and conditions and prices, please contact the nearest Infineon Technologies Office ([www.infineon.com](http://www.infineon.com)).

### **Warnings**

Due to technical requirements, components may contain dangerous substances. For information on the types in question, please contact the nearest Infineon Technologies Office.

Infineon Technologies components may be used in life-support devices or systems only with the express written approval of Infineon Technologies, if a failure of such components can reasonably be expected to cause the failure of that life-support device or system or to affect the safety or effectiveness of that device or system. Life support devices or systems are intended to be implanted in the human body or to support and/or maintain and sustain and/or protect human life. If they fail, it is reasonable to assume that the health of the user or other persons may be endangered.

**Revision History**

Page or Item	Subjects (major changes since previous revision)
Rev 2.0, 2012-07-31	

**Trademarks of Infineon Technologies AG**

AURIX™, BlueMoon™, C166™, CanPAK™, CIPOS™, CIPURSE™, COMNEON™, EconoPACK™, CoolMOS™, CoolSET™, CORECONTROL™, CROSSAVE™, DAVE™, EasyPIM™, EconoBRIDGE™, EconoDUAL™, EconoPIM™, EiceDRIVER™, eupec™, FCOS™, HITFET™, HybridPACK™, I<sup>2</sup>RF™, ISOFACE™, IsoPACK™, MIPAQ™, ModSTACK™, my-d™, NovalithIC™, OmniTune™, OptiMOS™, ORIGA™, PRIMARION™, PrimePACK™, PrimeSTACK™, PRO-SIL™, PROFET™, RASIC™, ReverSave™, SatRIC™, SIEGET™, SINDRION™, SIPMOS™, SMARTi™, SmartLEWIS™, SOLID FLASH™, TEMPFET™, thinQ!™, TRENCHSTOP™, TriCore™, X-GOLD™, X-PMU™, XMM™, XPOSYS™.

**Other Trademarks**

Advance Design System™ (ADS) of Agilent Technologies, AMBA™, ARM™, MULTI-ICE™, KEIL™, PRIMECELL™, REALVIEW™, THUMB™, μVision™ of ARM Limited, UK. AUTOSAR™ is licensed by AUTOSAR development partnership. Bluetooth™ of Bluetooth SIG Inc. CAT-iq™ of DECT Forum. COLOSSUS™, FirstGPS™ of Trimble Navigation Ltd. EMV™ of EMVCo, LLC (Visa Holdings Inc.). EPCOS™ of Epcos AG. FLEXGO™ of Microsoft Corporation. FlexRay™ is licensed by FlexRay Consortium. HYPERTERMINAL™ of Hilgraeve Incorporated. IEC™ of Commission Electrotechnique Internationale. IrDA™ of Infrared Data Association Corporation. ISO™ of INTERNATIONAL ORGANIZATION FOR STANDARDIZATION. MATLAB™ of MathWorks, Inc. MAXIM™ of Maxim Integrated Products, Inc. MICROTEC™, NUCLEUS™ of Mentor Graphics Corporation. Mifare™ of NXP. MIPI™ of MIPI Alliance, Inc. MIPS™ of MIPS Technologies, Inc., USA. muRata™ of MURATA MANUFACTURING CO., MICROWAVE OFFICE™ (MWO) of Applied Wave Research Inc., OmniVision™ of OmniVision Technologies, Inc. Openwave™ Openwave Systems Inc. RED HAT™ Red Hat, Inc. RFMD™ RF Micro Devices, Inc. SIRIUS™ of Sirius Satellite Radio Inc. SOLARIS™ of Sun Microsystems, Inc. SPANSION™ of Spansion LLC Ltd. Symbian™ of Symbian Software Limited. TAIYO YUDEN™ of Taiyo Yuden Co. TEAKLITE™ of CEVA, Inc. TEKTRONIX™ of Tektronix Inc. TOKO™ of TOKO KABUSHIKI KAISHA TA. UNIX™ of X/Open Company Limited. VERILOG™, PALLADIUM™ of Cadence Design Systems, Inc. VLYNQ™ of Texas Instruments Incorporated. VXWORKS™, WIND RIVER™ of WIND RIVER SYSTEMS, INC. ZETEX™ of Diodes Zetex Limited.

Last Trademarks Update 2010-10-26

## Table of Contents

	<b>Table of Contents</b> .....	4
	<b>List of Figures</b> .....	6
	<b>List of Tables</b> .....	7
<b>1</b>	<b>Overview</b> .....	8
<b>2</b>	<b>Block Diagram</b> .....	10
<b>3</b>	<b>Pin Configuration and Functionality</b> .....	11
3.1	Pin Configuration .....	11
3.2	Pin Functionality .....	12
<b>4</b>	<b>Functional Description</b> .....	14
4.1	Introduction .....	14
4.2	Supply .....	14
4.3	Internal Protection Features .....	15
4.3.1	Undervoltage Lockout (UVLO) .....	15
4.3.2	READY Status Output .....	15
4.3.3	Watchdog Timer .....	15
4.3.4	Active Shut-Down .....	15
4.4	Non-Inverting and Inverting Inputs .....	16
4.5	Driver Output .....	16
4.6	Two-Level Turn-Off .....	16
4.7	Minimal On Time / Off Time .....	17
4.8	External Protection Features .....	17
4.8.1	Desaturation Protection .....	17
4.8.2	Active Miller Clamp .....	17
4.8.3	Short Circuit Clamping .....	17
4.9	RESET .....	17
<b>5</b>	<b>Electrical Parameters</b> .....	18
5.1	Absolute Maximum Ratings .....	18
5.2	Operating Parameters .....	19
5.3	Recommended Operating Parameters .....	19
5.4	Electrical Characteristics .....	20
5.4.1	Voltage Supply .....	20
5.4.2	Logic Input and Output .....	21
5.4.3	Gate Driver .....	22
5.4.4	Active Miller Clamp .....	22
5.4.5	Short Circuit Clamping .....	23
5.4.6	Dynamic Characteristics .....	23
5.4.7	Desaturation Protection .....	24
5.4.8	Active Shut Down .....	25
5.4.9	Two-level Turn-off .....	25
<b>6</b>	<b>Insulation Characteristics</b> .....	26
6.1	Certified according to DIN EN 60747-5-2 (VDE 0884 Teil 2): 2003-01. Basic Insulation .....	26
6.2	Certified according to UL 1577 .....	26
6.3	Reliability .....	26
<b>7</b>	<b>Timing Diagrams</b> .....	27
<b>8</b>	<b>Package Outlines</b> .....	32

<b>9</b>	<b>Application Notes</b> .....	<b>33</b>
9.1	Reference Layout for Thermal Data .....	33
9.2	Printed Circuit Board Guidelines .....	33

## List of Figures

Figure 1	Typical Application . . . . .	9
Figure 2	Block Diagram 1ED020112-BT . . . . .	10
Figure 3	Pin Configuration PG-DSO-16-15 (top view) . . . . .	11
Figure 4	Application Example Bipolar Supply . . . . .	14
Figure 5	Application Example Unipolar Supply . . . . .	15
Figure 6	Propagation Delay, Rise and Fall Time . . . . .	27
Figure 7	Principle Switching Behavior . . . . .	27
Figure 8	Typical Switching Behavior . . . . .	27
Figure 9	DESAT Switch-OFF Behavior . . . . .	28
Figure 10	Short Switch ON Pulses . . . . .	28
Figure 11	Short Switch OFF Pulses . . . . .	29
Figure 12	Short Switch OFF Pulses, Ringing Suppression . . . . .	29
Figure 13	VCC2 Ramp Up . . . . .	30
Figure 14	VCC2 Ramp Down and VCC2 Drop . . . . .	30
Figure 15	Typical $T_{TLSET}$ Time over $C_{TLSET}$ Capacitance . . . . .	31
Figure 16	PG-DSO-16-15 (Plastic (Green) Dual Small Outline Package) . . . . .	32
Figure 17	Reference Layout for Thermal Data (Copper thickness 102 $\mu$ m) . . . . .	33

## List of Tables

Table 1	Pin Configuration	11
Table 2	Absolute Maximum Ratings	18
Table 3	Operating Parameters	19
Table 4	Recommended Operating Parameters	19
Table 5	Voltage Supply	20
Table 6	Logic Input and Output	21
Table 7	Gate Driver	22
Table 8	Active Miller Clamp	22
Table 9	Short Circuit Clamping	23
Table 10	Dynamic Characteristics	23
Table 11	Desaturation Protection	24
Table 12	Active Shut Down	25
Table 13	Two-level Turn-off	25
Table 14	According to DIN EN 60747-5-2	26
Table 15	According to UL 1577	26

## 1 Overview

### Main Features

- Single channel isolated IGBT Driver
- For 600 V/1200 V IGBTs
- 2 A rail-to-rail output
- Vcesat-detection
- Active Miller Clamp
- Two level turn off

### Product Highlights

- Coreless transformer isolated driver
- Basic insulation according to DIN EN 60747-5-2
- Integrated protection features
- Suitable for operation at high ambient temperature

### Typical Application

- Inverters for motor drives
- UPS systems
- Welding

### Description

The 1ED020I12-BT is a galvanic isolated single channel IGBT driver in PG-DSO-16-15 package that provides an output current capability of typically 2A.

All logic pins are 5V CMOS compatible and could be directly connected to a microcontroller.

The data transfer across galvanic isolation is realized by the integrated Coreless Transformer Technology.

The 1ED020I12-BT provides several protection features like IGBT two level turn off, desaturation protection, active Miller clamping and active shut down.



Product Name	Gate Drive Current	Package
1ED020I12-BT	±2 A	PG-DSO-16-15



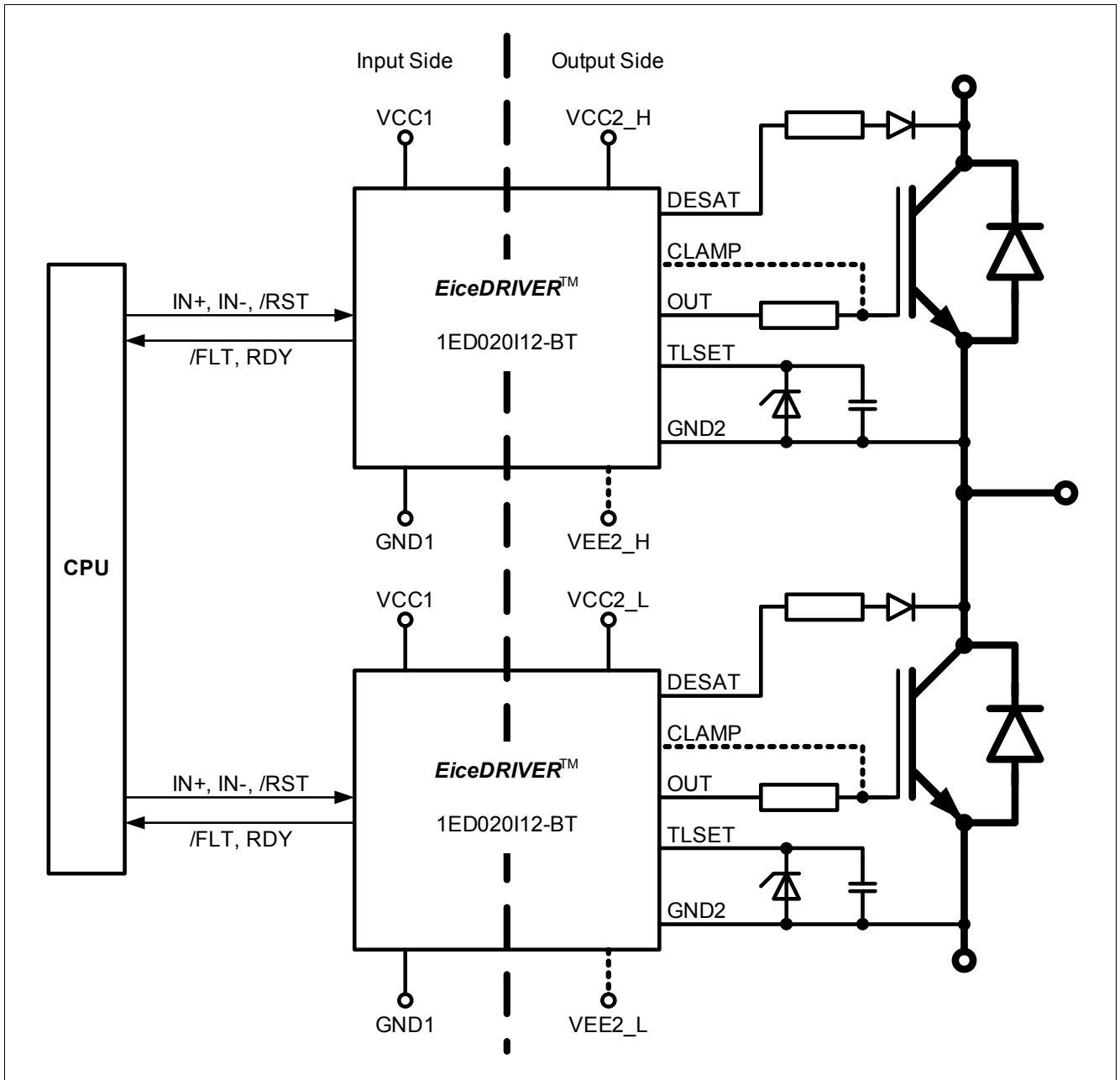

Figure 1 Typical Application

## 2 Block Diagram

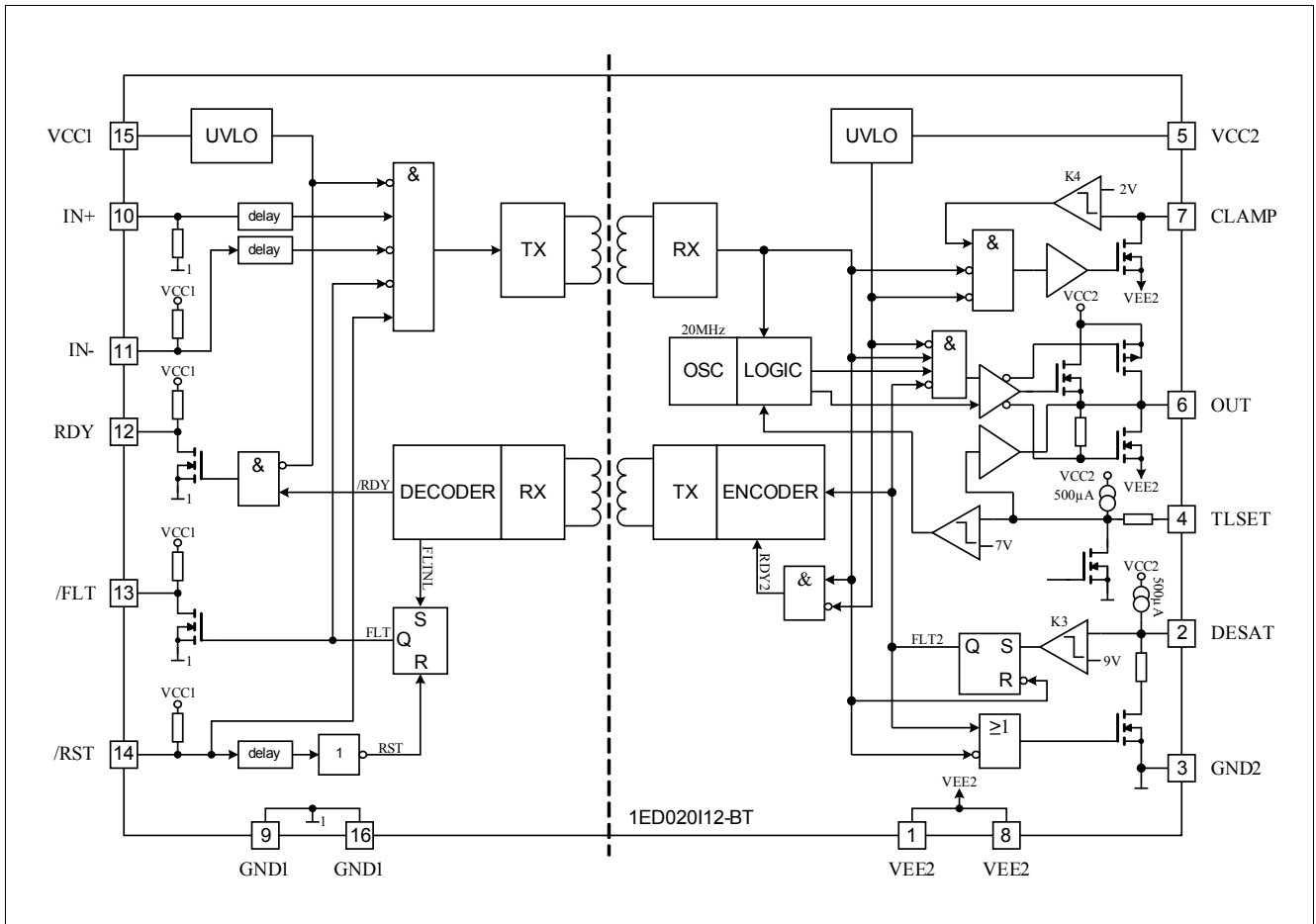

Figure 2 Block Diagram 1ED020112-BT

### 3 Pin Configuration and Functionality

#### 3.1 Pin Configuration

**Table 1 Pin Configuration**

Pin No.	Name	Function
1	VEE2	Negative power supply output side
2	DESAT	Desaturation protection
3	GND2	Signal ground output side
4	TLSET	Two level set
5	VCC2	Positive power supply output side
6	OUT	Driver output
7	CLAMP	Miller clamping
8	VEE2	Negative power supply output side
9	GND1	Ground input side
10	IN+	Non inverted driver input
11	IN-	Inverted driver input
12	RDY	Ready output
13	/FLT	Fault output, low active
14	/RST	Reset input, low active
15	VCC1	Positive power supply input side
16	GND1	Ground input side

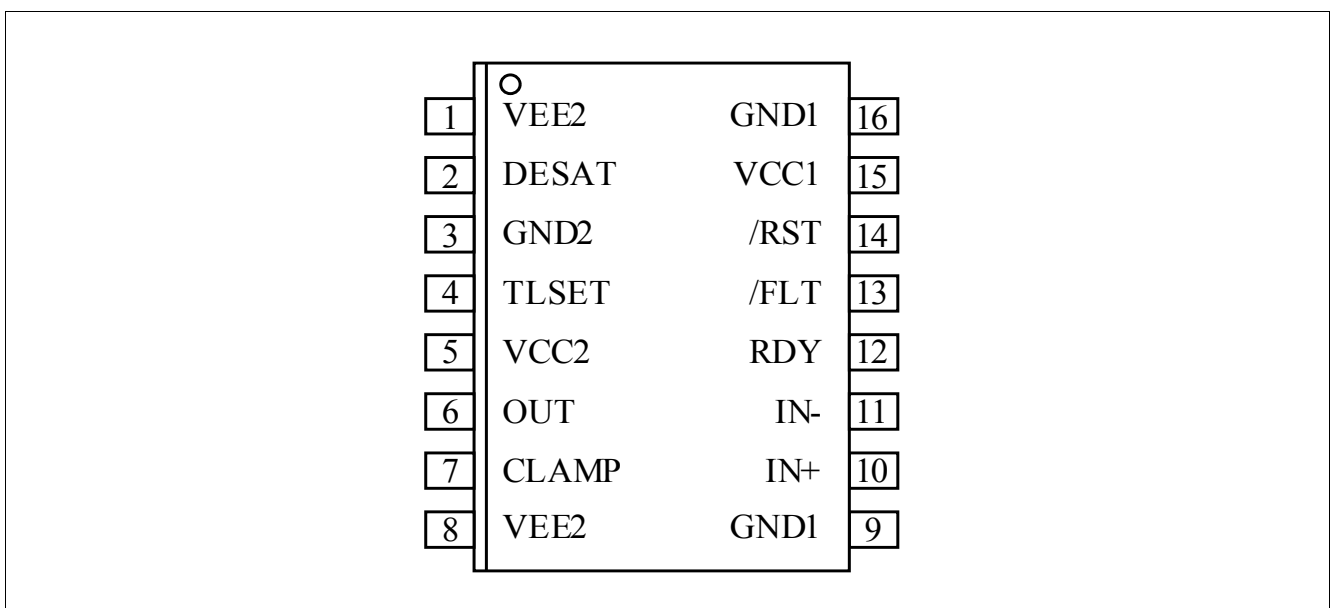

**Figure 3 Pin Configuration PG-DSO-16-15 (top view)**

## 3.2 Pin Functionality

### GND1

Ground connection of the input side.

### IN+ Non Inverting Driver Input

IN+ control signal for the driver output if IN- is set to low. (The IGBT is on if IN+ = high and IN- = low)

A minimum pulse width is defined to make the IC robust against glitches at IN+. An internal Pull-Down-Resistor ensures IGBT Off-State.

### IN- Inverting Driver Input

IN- control signal for driver output if IN+ is set to high. (IGBT is on if IN- = low and IN+ = high)

A minimum pulse width is defined to make the IC robust against glitches at IN-. An internal Pull-Up-Resistor ensures IGBT Off-State.

### /RST Reset Input

**Function 1:** Enable/shutdown of the input chip. (The IGBT is off if /RST = low). A minimum pulse width is defined to make the IC robust against glitches at /RST.

**Function 2:** Resets the DESAT-FAULT-state of the chip if /RST is low for a time  $T_{RST}$ . An internal Pull-Up-Resistor is used to ensure /FLT status output.

### /FLT Fault Output

Open-drain output to report a desaturation error of the IGBT (/FLT is low if desaturation occurs)

### RDY Ready Status

Open-drain output to report the correct operation of the device (RDY = high if both chips are above the UVLO level and the internal chip transmission is faultless).

### VCC1

5 V power supply of the input chip

### VEE2

Negative power supply pins of the output chip. If no negative supply voltage is available, all VEE2 pins have to be connected to GND2.

### DESAT Desaturation Detection Input

Monitoring of the IGBT saturation voltage ( $V_{CE}$ ) to detect desaturation caused by short circuits. If OUT is high,  $V_{CE}$  is above a defined value and a certain blanking time has expired, the desaturation protection is activated and the IGBT is switched off. The blanking time is adjustable by an external capacitor.

### CLAMP Miller Clamping

Ties the gate voltage to ground after the IGBT has been switched off at a defined voltage to avoid a parasitic switch-on of the IGBT. During turn-off, the gate voltage is monitored and the clamp output is activated when the gate voltage goes below 2 V above VEE2.

**GND2 Reference Ground**

Reference ground of the output chip.

**OUT Driver Output**

Output pin to drive an IGBT. The voltage is switched between VEE2 and VCC2. In normal operating mode Vout is controlled by IN+, IN- and /RST. During error mode (UVLO, internal error or DESAT) Vout is set to VEE2 independent of the input control signals.

**VCC2**

Positive power supply pin of the output side.

**TLSET Two Level Turn Off Adjust**

Circuitry at TLSET adjust the two level turn off time with an external capacitor to GND2 and the two level voltage with an external Zener diode to GND2, for wave forms please see [Figure 9](#).

## 4 Functional Description

### 4.1 Introduction

The 1ED020112-BT is an advanced IGBT gate driver for motor drives typical greater 10 kW. Control and protection functions are included to make possible the design of high reliability systems.

The device consists of two galvanic separated parts. The input chip can be directly connected to a standard 5 V DSP or microcontroller with CMOS in/output and the output chip is connected to the high voltage side.

An effective active Miller clamp function avoids the need of negative gate driving in some applications and allows the use of a simple bootstrap supply for the high side driver.

A rail-to-rail driver output enables the user to provide easy clamping of the IGBTs gate voltage during short circuit of the IGBT. So an increase of short circuit current due to the feedback via the Miller capacitance can be avoided. Further, a rail-to-rail output reduces power dissipation.

The device also includes an IGBT desaturation protection with a /FLT status output.

A two-level turn-off feature with adjustable delay protects against excessive overvoltage at turn-off in case of overcurrent or short circuit condition. The same delay is applied at turn-on to prevent pulse width distortion.

A READY status output reports if the device is supplied and operates correctly.

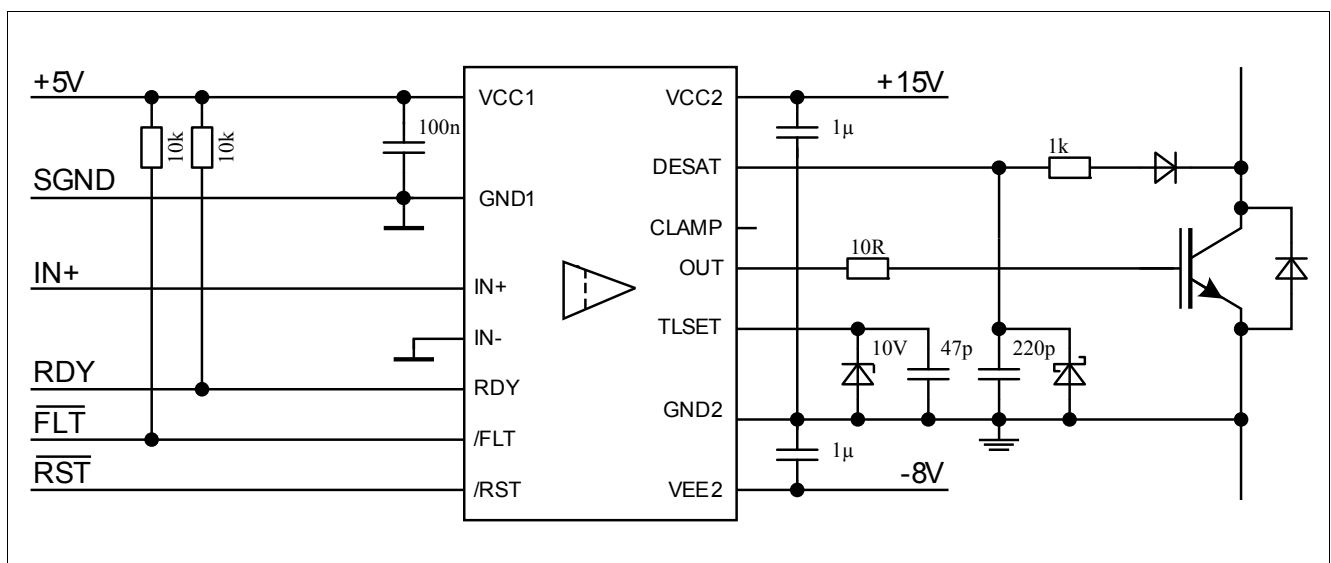

Figure 4 Application Example Bipolar Supply

### 4.2 Supply

The driver 1ED020112-BT is designed to support two different supply configurations, bipolar supply and unipolar supply.

In bipolar supply the driver is typically supplied with a positive voltage of 15V at VCC2 and a negative voltage of -8V at VEE2, refer to [Figure 4](#). Negative supply prevents a dynamic turn on due to the additional charge which is generated from IGBT input capacitance times negative supply voltage. If an appropriate negative supply voltage is used, connecting CLAMP to IGBT gate is redundant and therefore typically not necessary.

For unipolar supply configuration the driver is typically supplied with a positive voltage of 15V at VCC2. Erratically dynamic turn on of the IGBT could be prevented with active Miller clamp function, so CLAMP output is directly connected to IGBT gate, refer to [Figure 5](#).

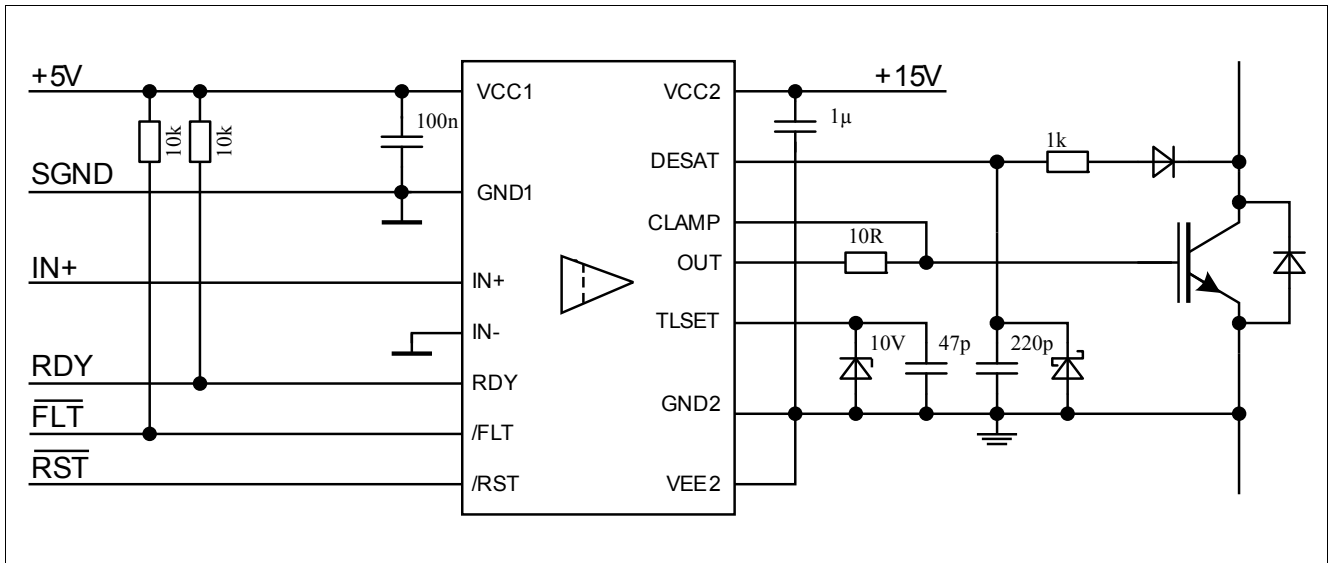

Figure 5 Application Example Unipolar Supply

## 4.3 Internal Protection Features

### 4.3.1 Undervoltage Lockout (UVLO)

To ensure correct switching of IGBTs the device is equipped with an undervoltage lockout for both chips, refer to [Figure 13](#) and [Figure 14](#).

If the power supply voltage  $V_{VCC1}$  of the input chip drops below  $V_{UVLOL1}$  a turn-off signal is sent to the output chip before power-down. The IGBT is switched off and the signals at IN+ and IN- are ignored as long as  $V_{VCC1}$  reaches the power-up voltage  $V_{UVLOH1}$ .

If the power supply voltage  $V_{VCC2}$  of the output chip goes down below  $V_{UVLOL2}$  the IGBT is switched off and signals from the input chip are ignored as long as  $V_{VCC2}$  reaches the power-up voltage  $V_{UVLOH2}$ . VEE2 is not monitored, otherwise negative supply voltage range from 0 V to -12 V would not be possible.

### 4.3.2 READY Status Output

The READY output at pin /RDY shows the status of three internal protection features.

- UVLO of the input chip
- UVLO of the output chip after a short delay
- Internal signal transmission after a short delay

It is not necessary to reset the READY signal since its state only depends on the status of the former mentioned protection signals.

### 4.3.3 Watchdog Timer

During normal operation the internal signal transmission is monitored by a watchdog timer. If the transmission fails for a given time, the IGBT is switched off and the READY output reports an internal error.

### 4.3.4 Active Shut-Down

The Active Shut-Down feature ensures a safe IGBT off-state if the output chip is not connected to the power supply, IGBT gate is clamped at OUT to VEE2.

#### 4.4 Non-Inverting and Inverting Inputs

There are two possible input modes to control the IGBT. At non-inverting mode IN+ controls the driver output while IN- is set to low. At inverting mode IN- controls the driver output while IN+ is set to high, refer to [Figure 7](#). A minimum input pulse width is defined to filter occasional glitches.

#### 4.5 Driver Output

The output driver section uses only MOSFETs to provide a rail-to-rail output. This feature permits that tight control of gate voltage during on-state and short circuit can be maintained as long as the drivers supply is stable. Due to the low internal voltage drop, switching behaviour of the IGBT is predominantly governed by the gate resistor. Furthermore, it reduces the power to be dissipated by the driver.

#### 4.6 Two-Level Turn-Off

The Two-Level Turn-OFF introduces a second turn off voltage level at the driver output in between ON- and OFF-level, refer to [Figure 8](#). This additional level ensures lower  $V_{CE}$  overshoots at turn off by reducing gate emitter voltage of the IGBT at short circuits or over current events. The  $V_{GE}$  level is adjusting the current of the IGBT at the end two level turn off interval, the required timing is depending on stray inductance and over current at beginning of two level turn off interval.

Reference voltage level and hold up time could be adjusted at TLSET pin. The reference voltage is set by the required Zener diode connected between pin TLSET and GND2. The holdup time is set by the capacitor connected to the same pin TLSET and GND2.

The hold time can be adjusted during switch on using the whole capacitance connected at pin TLSET including capacitor, parasitic wiring capacitance and junction capacitance of Zener diode. When a switch on signal is given the IC starts to discharge  $C_{TLSET}$ . Discharging  $C_{TLSET}$  is stopped after 500 ns. Then  $C_{TLSET}$  is charged with an internal charge current  $I_{TLSET}$ . When the voltage of the capacitor  $C_{TLSET}$  exceeds 7 V a second current source starts charging  $C_{TLSET}$  up to  $V_{ZDIODE}$ . At the end of this discharge-charge cycle the gate driver is switched on.

The time between IN initiated switch-on signal (minus an internal propagation delay of approximately 200 ns) and switch-on of the gate drive is sampled and stored digitally. It represents the two level turn off set time  $T_{TLSET}$  during switch-off. Due to digitalization the  $t_{pdon}$  time can vary in time steps of 50 ns.

If switch off is initiated from IN+, IN- or /RST signal, the gate driver is switched off immediately after internal propagation delay of approximately 200 ns and  $V_{OUT}$  begins to decrease to the second gate voltage level.

For switch off initiated by DESAT, the gate driver switch off is delayed by desaturation sense to OUT delay, afterwards  $V_{OUT}$  begins to decrease to the second gate voltage level.

For reaching second gate voltage level the output voltage  $V_{OUT}$  is sensed and compared with the Zener voltage  $V_{ZDIODE}$ . When  $V_{OUT}$  falls below the reference voltage  $V_{ZDIODE}$  of the Zener diode the switch off process is interrupted and  $V_{OUT}$  is adjusted to  $V_{ZDIODE}$ . OUT is switched to VEE2 after the holdup time has passed.

The Two-Level Turn-OFF function cannot be disabled.



## 4.7 Minimal On Time / Off Time

The 1ED020112-BT driver requires minimal on and off time for proper operation in the application. Minimal on time must be greater than the adjustable two level plateau time  $T_{TLSET}$ , shorter on times will be suppressed by generating of the plateau time refer to [Figure 10](#). Due to the short on time, the voltage at TLSET pin does not reach the comparator threshold; therefore the driver does not turn on. A similar principle takes place for off time. Minimal off time must be greater than  $T_{TLSET}$ ; shorter off times will be suppressed, which means OUT stays on refer to [Figure 11](#). A two level turn off plateau cannot be shortened by the driver. If the driver has entered the turn off sequence it cannot switch off due to the fact, that the driver has already entered the shut off mode. But if the driver input signal is turned on again, it will leave the lower level after  $T_{TLSET}$  time by switching OUT to high, refer to [Figure 12](#).

## 4.8 External Protection Features

### 4.8.1 Desaturation Protection

A desaturation protection ensures the protection of the IGBT at short circuit. When the DESAT voltage goes up and reaches 9 V, the output is driven low, refer to [Figure 9](#). Further, the /FLT output is activated. A programmable blanking time is used to allow enough time for IGBT saturation. Blanking time is provided by a highly precise internal current source and an external capacitor.

### 4.8.2 Active Miller Clamp

In a half bridge configuration the switched off IGBT tends to dynamically turn on during turn on phase of the opposite IGBT. A Miller clamp allows sinking the Miller current across a low impedance path in this high  $dV/dt$  situation. Therefore in many applications, the use of a negative supply voltage can be avoided.

During turn-off, the gate voltage is monitored and the clamp output is activated when the gate voltage goes below typical 2 V (related to VEE2). The clamp is designed for a Miller current up to 2 A.

### 4.8.3 Short Circuit Clamping

During short circuit the IGBTs gate voltage tends to rise because of the feedback via the Miller capacitance. An additional protection circuit connected to OUT and CLAMP limits this voltage to a value slightly higher than the supply voltage. A current of maximum 500 mA for 10  $\mu$ s may be fed back to the supply through one of this paths. If higher currents are expected or a tighter clamping is desired external Schottky diodes may be added.

## 4.9 RESET

The reset input has two functions.

Firstly, /RST is in charge of setting back the /FLT output. If /RST is low longer than a given time, /FLT will be cleared at the rising edge of /RST, refer to [Figure 9](#); otherwise, it will remain unchanged. Moreover, it works as enable/shutdown of the input logic, refer to [Figure 7](#).

## 5 Electrical Parameters

### 5.1 Absolute Maximum Ratings

Note: Absolute maximum ratings are defined as ratings, which when being exceeded may lead to destruction of the integrated circuit. Unless otherwise noted all parameters refer to GND1.

**Table 2 Absolute Maximum Ratings**

Parameter	Symbol	Values		Unit	Note / Test Condition
		Min.	Max.		
Positive power supply output side	$V_{VCC2}$	-0.3	20	V	1)
Negative power supply output side	$V_{VEE2}$	-12	0.3	V	1)
Maximum power supply voltage output side ( $V_{VCC2} - V_{VEE2}$ )	$V_{max2}$	–	28	V	–
Gate driver output	$V_{OUT}$	$V_{VEE2}-0.3$	$V_{max2}+0.3$	V	–
Gate driver high output maximum current	$I_{OUT}$	–	2.4	A	$t = 2 \mu s$
Gate & Clamp driver low output maximum current	$I_{OUT}$	–	2.4	A	$t = 2 \mu s$
Maximum short circuit clamping time	$t_{CLP}$	–	10	$\mu s$	$I_{CLAMP/OUT} = 500 \text{ mA}$
Positive power supply input side	$V_{VCC1}$	-0.3	6.5	V	–
Logic input voltages (IN+, IN-, RST)	$V_{LogicIN}$	-0.3	6.5	V	–
Open-drain Logic output voltage ( $\overline{FLT}$ )	$V_{FLT\#}$	-0.3	6.5	V	–
Open-drain Logic output voltage (RDY)	$V_{RDY}$	-0.3	6.5	V	–
Open-drain Logic output current ( $\overline{FLT}$ )	$I_{FLT\#}$	–	10	mA	–
Open-drain Logic output current (RDY)	$I_{RDY}$	–	10	mA	–
Pin DESAT voltage	$V_{DESAT}$	-0.3	$V_{VCC2} + 0.3$	V	1)
Pin CLAMP voltage	$V_{CLAMP}$	-0.3	$V_{VCC2} + 0.3^{2)}$	V	3)
Junction temperature	$T_J$	-40	150	°C	–
Storage temperature	$T_S$	-55	150	°C	–
Power dissipation, per input part	$P_{D, IN}$	–	100	mW	4) @ $T_A = 25^\circ C$
Power dissipation, per output part	$P_{D, OUT}$	–	700	mW	4) @ $T_A = 25^\circ C$
Thermal resistance (Input part)	$R_{THJA, IN}$	–	160	K/W	4) @ $T_A = 25^\circ C$
Thermal resistance (Output chip active)	$R_{THJA, OUT}$	–	125	K/W	4) @ $T_A = 25^\circ C$
ESD Capability	$V_{ESD}$	–	1.5	kV	Human Body Model <sup>5)</sup>

1) With respect to GND2.

2) May be exceeded during short circuit clamping.

3) With respect to VEE2.

**Electrical Parameters Operating Parameters**

4) Output IC power dissipation is derated linearly at 10 mW/°C above 62°C. Input IC power dissipation does not require derating. See [Figure 17](#) for reference layouts for these thermal data. Thermal performance may change significantly with layout and heat dissipation of components in close proximity.

5) According to EIA/JESD22-A114-B (discharging a 100 pF capacitor through a 1.5 kΩ series resistor).

## 5.2 Operating Parameters

*Note: Within the operating range the IC operates as described in the functional description. Unless otherwise noted all parameters refer to GND1.*

**Table 3 Operating Parameters**

Parameter	Symbol	Values		Unit	Note / Test Condition
		Min.	Max.		
Positive power supply output side	$V_{VCC2}$	13	20	V	1)
Negative power supply output side	$V_{VEE2}$	-12	0	V	1)
Maximum power supply voltage output side ( $V_{VCC2} - V_{VEE2}$ )	$V_{max2}$	–	28	V	–
Positive power supply input side	$V_{VCC1}$	4.5	5.5	V	–
Logic input voltages (IN+, IN-, RST)	$V_{LogicIN}$	-0.3	5.5	V	–
Pin CLAMP voltage	$V_{CLAMP}$	$V_{VEE2} - 0.3$	$V_{VCC2}^{2)}$	V	–
Pin DESAT voltage	$V_{DESAT}$	-0.3	$V_{VCC2}$	V	1)
Pin TLSET voltage	$V_{TLSET}$	-0.3	$V_{VCC2}$	V	1)
Ambient temperature	$T_A$	-40	105	°C	–
Common mode transient immunity <sup>3)</sup>	$ dV_{ISO}/dt $	–	50	kV/μs	@ 500 V

1) With respect to GND2.

2) May be exceeded during short circuit clamping.

3) The parameter is not subject to production test - verified by design/characterization

## 5.3 Recommended Operating Parameters

*Note: Unless otherwise noted all parameters refer to GND1.*

**Table 4 Recommended Operating Parameters**

Parameter	Symbol	Value	Unit	Note / Test Condition
Positive power supply output side	$V_{VCC2}$	15	V	1)
Negative power supply output side	$V_{VEE2}$	-8	V	1)
Positive power supply input side	$V_{VCC1}$	5	V	–

1) With respect to GND2.

## 5.4 Electrical Characteristics

Note: The electrical characteristics include the spread of values in supply voltages, load and junction temperatures given below. Typical values represent the median values at  $T_A = 25^\circ\text{C}$ . Unless otherwise noted all voltages are given with respect to their respective GND (GND1 for pins 9 to 16, GND2 for pins 1 to 8).

### 5.4.1 Voltage Supply

**Table 5 Voltage Supply**

Parameter	Symbol	Values			Unit	Note / Test Condition
		Min.	Typ.	Max.		
UVLO Threshold Input Chip	$V_{UVLOH1}$	–	4.1	4.3	V	–
	$V_{UVLOL1}$	3.5	3.8	–	V	–
UVLO Hysteresis Input Chip ( $V_{UVLOH1} - V_{UVLOL1}$ )	$V_{HYS1}$	0.15	–	–	V	–
UVLO Threshold Output Chip	$V_{UVLOH2}$	–	12.0	12.6	V	–
	$V_{UVLOL2}$	10.4	11.0	–	V	–
UVLO Hysteresis Output Chip ( $V_{UVLOH1} - V_{UVLOL1}$ )	$V_{HYS2}$	0.7	0.9	–	V	–
Quiescent Current Input Chip	$I_{Q1}$	–	7	9	mA	$V_{VCC1} = 5\text{ V}$ IN+ = High, IN- = Low =>OUT = High, RDY = High, /FLT = High
Quiescent Current Output Chip	$I_{Q2}$	–	4.5	6	mA	$V_{VCC2} = 15\text{ V}$ $V_{VEE2} = -8\text{ V}$ IN+ = High, IN- = Low =>OUT = High, RDY = High, /FLT = High

**5.4.2 Logic Input and Output**
**Table 6 Logic Input and Output**

Parameter	Symbol	Values			Unit	Note / Test Condition
		Min.	Typ.	Max.		
IN+,IN-, $\overline{\text{RST}}$ Low Input Voltage	$V_{\text{IN+L}},$ $V_{\text{IN-L}},$ $V_{\text{RSTL\#}}$	–	–	1.5	V	–
IN+,IN-, $\overline{\text{RST}}$ High Input Voltage	$V_{\text{IN+H}},$ $V_{\text{IN-H}},$ $V_{\text{RSTH\#}}$	3.5	–	–	V	–
IN-, $\overline{\text{RST}}$ Input Current	$I_{\text{IN-}}, I_{\text{RST\#}}$	-400	-100	–	μA	$V_{\text{IN-}} = \text{GND1}$ $V_{\text{RST\#}} = \text{GND1}$
IN+ Input Current	$I_{\text{IN+}},$	–	100	400	μA	$V_{\text{IN+}} = \text{VCC1}$
RDY, $\overline{\text{FLT}}$ Pull Up Current	$I_{\text{PRDY}}, I_{\text{PFLT\#}}$	-400	-100	–	μA	$V_{\text{RDY}} = \text{GND1}$ $V_{\text{FLT\#}} = \text{GND1}$
Input Pulse Suppression IN+, IN-	$T_{\text{MININ+}},$ $T_{\text{MININ-}}$	30	40	–	ns	–
Input Pulse Suppression $\overline{\text{RST}}$ for ENABLE/SHUTDOWN	$T_{\text{MINRST}}$	30	40	–	ns	–
Pulse Width $\overline{\text{RST}}$ for Reseting FLT	$T_{\text{RST}}$	800	–	–	ns	–
$\overline{\text{FLT}}$ Low Voltage	$V_{\text{FLTL}}$	–	–	300	mV	$I_{\text{SINK(FLT\#)}} = 5 \text{ mA}$
RDY Low Voltage	$V_{\text{RDYL}}$	–	–	300	mV	$I_{\text{SINK(RDY)}} = 5 \text{ mA}$

### 5.4.3 Gate Driver

**Table 7 Gate Driver**

Parameter	Symbol	Values			Unit	Note / Test Condition
		Min.	Typ.	Max.		
High Level Output Voltage	$V_{\text{OUTH1}}$	$V_{\text{VCC2}}-1.2$	$V_{\text{VCC2}}-0.8$	–	V	$I_{\text{OUTH}} = -20 \text{ mA}$
	$V_{\text{OUTH2}}$	$V_{\text{VCC2}}-2.5$	$V_{\text{VCC2}}-2.0$	–	V	$I_{\text{OUTH}} = -200 \text{ mA}$
	$V_{\text{OUTH3}}$	$V_{\text{VCC2}}-9$	$V_{\text{VCC2}}-5$	–	V	$I_{\text{OUTH}} = -1 \text{ A}$
	$V_{\text{OUTH4}}$	–	$V_{\text{VCC2}}-10$	–	V	$I_{\text{OUTH}} = -2 \text{ A}$
High Level Output Peak Current	$I_{\text{OUTH}}$	-1.5	-2.0	–	A	IN+ = High, IN- = Low; OUT = High
Low Level Output Voltage	$V_{\text{OUTL1}}$	–	$V_{\text{VEE2}}+0.04$	$V_{\text{VEE2}}+0.09$	V	$I_{\text{OUTL}} = 20 \text{ mA}$
	$V_{\text{OUTL2}}$	–	$V_{\text{VEE2}}+0.3$	$V_{\text{VEE2}}+0.85$	V	$I_{\text{OUTL}} = 200 \text{ mA}$
	$V_{\text{OUTL3}}$	–	$V_{\text{VEE2}}+2.1$	$V_{\text{VEE2}}+5.0$	V	$I_{\text{OUTL}} = 1 \text{ A}$
	$V_{\text{OUTL4}}$	–	$V_{\text{VEE2}}+7$	–	V	$I_{\text{OUTL}} = 2 \text{ A}$
Low Level Output Peak Current	$I_{\text{OUTL}}$	1.5	2.0	–	A	IN+ = Low, IN- = Low; OUT = Low, $V_{\text{VCC2}} = 15 \text{ V}$ , $V_{\text{VEE2}} = -8 \text{ V}$

### 5.4.4 Active Miller Clamp

**Table 8 Active Miller Clamp**

Parameter	Symbol	Values			Unit	Note / Test Condition
		Min.	Typ.	Max.		
Low Level Clamp Voltage	$V_{\text{CLAMPL1}}$	–	$V_{\text{VEE2}}+0.03$	$V_{\text{VEE2}} +0.08$	V	$I_{\text{OUTL}} = 20 \text{ mA}$
	$V_{\text{CLAMPL2}}$	–	$V_{\text{VEE2}}+0.3$	$V_{\text{VEE2}} +0.8$	V	$I_{\text{OUTL}} = 200 \text{ mA}$
	$V_{\text{CLAMPL3}}$	–	$V_{\text{VEE2}}+1.9$	$V_{\text{VEE2}} +4.8$	V	$I_{\text{OUTL}} = 1 \text{ A}$
Low Level Clamp Current	$I_{\text{CLAMPL}}$	2	–	–	A	1)
Clamp Threshold Voltage	$V_{\text{CLAMP}}$	1.6	2.1	2.4	V	Related to VEE2

1) The parameter is not subject to production test - verified by design/characterization

### 5.4.5 Short Circuit Clamping

**Table 9 Short Circuit Clamping**

Parameter	Symbol	Values			Unit	Note / Test Condition
		Min.	Typ.	Max.		
Clamping voltage (OUT) ( $V_{OUT} - V_{VCC2}$ )	$V_{CLPout}$	–	0.8	1.3	V	IN+ = High, IN- = Low, OUT = High $I_{OUT} = 500$ mA (pulse test, $t_{CLPmax} = 10$ $\mu$ s)
Clamping voltage (CLAMP) ( $V_{VCLAMP} - V_{VCC2}$ )	$V_{CLPclamp}$	–	1.3	–	V	IN+ = High, IN- = Low, OUT = High $I_{CLAMP} = 500$ mA (pulse test, $t_{CLPmax} = 10$ $\mu$ s)
Clamping voltage (CLAMP)	$V_{CLPclamp}$	–	0.7	1.1	V	IN+ = High, IN- = Low, OUT = High $I_{CLAMP} = 20$ mA

### 5.4.6 Dynamic Characteristics

Dynamic characteristics are measured with  $V_{VCC1} = 5$  V,  $V_{VCC2} = 15$  V and  $V_{VEE2} = -8$  V.

**Table 10 Dynamic Characteristics**

Parameter	Symbol	Values			Unit	Note / Test Condition
		Min.	Typ.	Max.		
IN+, IN- input to output propagation delay ON and OFF	$T_{PDON}$	1.5	1.75	2.0	$\mu$ s	$C_{TLSET} = 0$ , $T_A = 25^\circ$ C
IN+, IN- input to output propagation delay distortion ( $T_{PDOFF} - T_{PDON}$ )	$T_{PDISTO}$	-40	-10	20	ns	$C_{TLSET} = 0$ , $T_A = 25^\circ$ C
IN+, IN- input to output propagation delay ON variation due to temp	$T_{PDONt}$	–	–	200	ns	<sup>1)</sup> $C_{TLSET} = 0$
IN+, IN- input to output propagation delay OFF variation due to temp	$T_{PDOFFt}$	–	–	230	ns	<sup>1)</sup> $C_{TLSET} = 0$
IN+, IN- input to output propagation delay distortion variation due to temp ( $T_{PDOFF} - T_{PDON}$ )	$T_{PDISTOt}$	–	–	25	ns	<sup>1)</sup> $C_{TLSET} = 0$
Rise Time	$T_{RISE}$	10	30	60	ns	$C_{LOAD} = 1$ nF, $V_L$ 10%, $V_H$ 90%
		150	400	800	ns	$C_{LOAD} = 34$ nF $V_L$ 10%, $V_H$ 90%

**Table 10 Dynamic Characteristics (cont'd)**

Parameter	Symbol	Values			Unit	Note / Test Condition
		Min.	Typ.	Max.		
Fall Time	$T_{\text{FALL}}$	10	20	40	ns	$C_{\text{LOAD}} = 1 \text{ nF}$ $V_{\text{L}} 10\%, V_{\text{H}} 90\%$
		100	250	500	ns	$C_{\text{LOAD}} = 34 \text{ nF}$ $V_{\text{L}} 10\%, V_{\text{H}} 90\%$

1) The parameter is not subject to production test - verified by design/characterization

### 5.4.7 Desaturation Protection

**Table 11 Desaturation Protection**

Parameter	Symbol	Values			Unit	Note / Test Condition
		Min.	Typ.	Max.		
Blanking Capacitor Charge Current	$I_{\text{DESATC}}$	450	500	550	$\mu\text{A}$	$V_{\text{VCC2}} = 15 \text{ V}$ , $V_{\text{VEE2}} = -8 \text{ V}$ $V_{\text{DESAT}} = 2 \text{ V}$
Blanking Capacitor Discharge Current	$I_{\text{DESATD}}$	11	15	–	mA	$V_{\text{VCC2}} = 15 \text{ V}$ , $V_{\text{VEE2}} = -8 \text{ V}$ $V_{\text{DESAT}} = 6 \text{ V}$
Desaturation Reference Level	$V_{\text{DESAT}}$	8.5	9	9.5	V	$V_{\text{VCC2}} = 15 \text{ V}$
Desaturation Sense to OUT TLTO	$T_{\text{DESATOUT}}$	–	250	320	ns	$V_{\text{OUT}} = 90\%$ $C_{\text{LOAD}} = 1 \text{ nF}$
Desaturation Sense to FLT Low Delay	$T_{\text{DESATFLT}}$	–	–	2.25	$\mu\text{s}$	$V_{\text{FLT}\#} = 10\%$ ; $I_{\text{FLT}\#} = 5 \text{ mA}$
Desaturation Low Voltage	$V_{\text{DESATL}}$	40	70	110	mV	IN+=Low, IN-=Low, OUT=Low



### 5.4.8 Active Shut Down

**Table 12 Active Shut Down**

Parameter	Symbol	Values			Unit	Note / Test Condition
		Min.	Typ.	Max.		
Active Shut Down Voltage	$V_{ACTSD}^{1)}$	–	–	2.0	V	$I_{OUT} = -200$ mA, $V_{CC2}$ open

1) With reference to VEE2

### 5.4.9 Two-level Turn-off

**Table 13 Two-level Turn-off**

Parameter	Symbol	Values			Unit	Note / Test Condition
		Min.	Typ.	Max.		
External reference voltage range (Zener-Diode)	$V_{ZDIODE}$	7.5	–	$V_{CC2}-0.5$	V	–
Reference Voltage for setting two-level delay time	$V_{TLSET}$	6.6	7	7.3	V	–
Current for setting two-level delay time and external reference voltage (Zener-Diode)	$I_{TLSET}$	420	500	550	μA	$V_{TLSET} = 10$ V
External Capacitance Range	$C_{TLSET}$	0	–	220	pF	–

## 6 Insulation Characteristics

Insulation characteristics are guaranteed only within the safety maximum ratings which must be ensured by protective circuits in application. Surface mount classification is class A in accordance with CECC00802.

This coupler is suitable for “basic insulation” only within the safety ratings. Compliance with the safety ratings shall be ensured by means of suitable protective circuits.

### 6.1 Certified according to DIN EN 60747-5-2 (VDE 0884 Teil 2): 2003-01. Basic Insulation

**Table 14 According to DIN EN 60747-5-2**

Description	Symbol	Characteristic	Unit
Installation classification per EN 60664-1, Table 1 for rated mains voltage $\leq 150 V_{RMS}$ for rated mains voltage $\leq 300 V_{RMS}$ for rated mains voltage $\leq 600 V_{RMS}$		I-IV I-III I-II	–
Climatic Classification		40/105/21	–
Pollution Degree (EN 60664-1)		2	–
Minimum External Clearance	CLR	8.12	mm
Minimum External Creepage	CPG	8.24	mm
Minimum Comparative Tracking Index	CTI	175	–
Maximum Repetitive Insulation Voltage	$V_{IORM}$	1420	$V_{PEAK}$
Input to output test voltage, method b <sup>1)</sup> $V_{IORM} * 1.875 = V_{PR}$ , 100% production test with $t_m = 1$ sec, partial discharge $< 5$ pC	$V_{PR}$	2663	$V_{PEAK}$
Input to output test voltage, method a <sup>1)</sup> $V_{IORM} * 1.6 = V_{PR}$ , 100% production test with $t_m = 60$ sec, partial discharge $< 5$ pC	$V_{PR}$	2272	$V_{PEAK}$
Highest Allowable Overvoltage	$V_{IOTM}$	6000	$V_{PEAK}$
Maximum Surge Insulation Voltage	$V_{IOSM}$	6000	V
Insulation Resistance at $T_s$ , $V_{IO} = 500$ V	$R_{IO}$	$> 10^9$	$\Omega$

1) Refer to VDE 0884 for a detailed description of Method a and Method b partial discharge test profiles.

### 6.2 Recognized under UL 1577

**Table 15 Recognized under UL 1577**

Description	Symbol	Characteristic	Unit
Insulation Withstand Voltage / 1 min	$V_{ISO}$	3750	$V_{rms}$
Insulation Test Voltage / 1 s	$V_{ISO}$	4500	$V_{rms}$

### 6.3 Reliability

For Qualification Report please contact your local Infineon Technologies office.

## 7 Timing Diagrams

All diagrams related to the Two-level switch-off feature

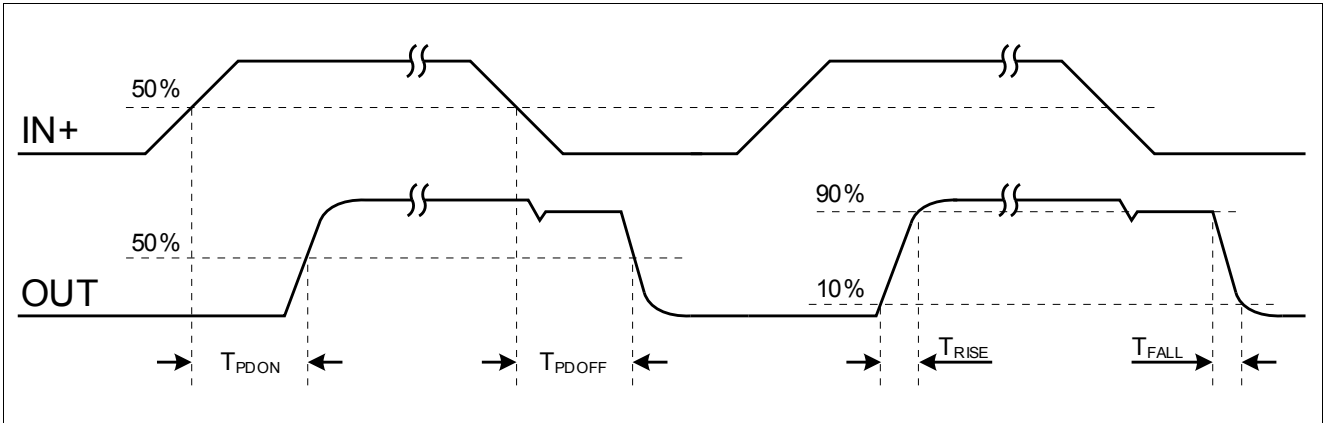

Figure 6 Propagation Delay, Rise and Fall Time

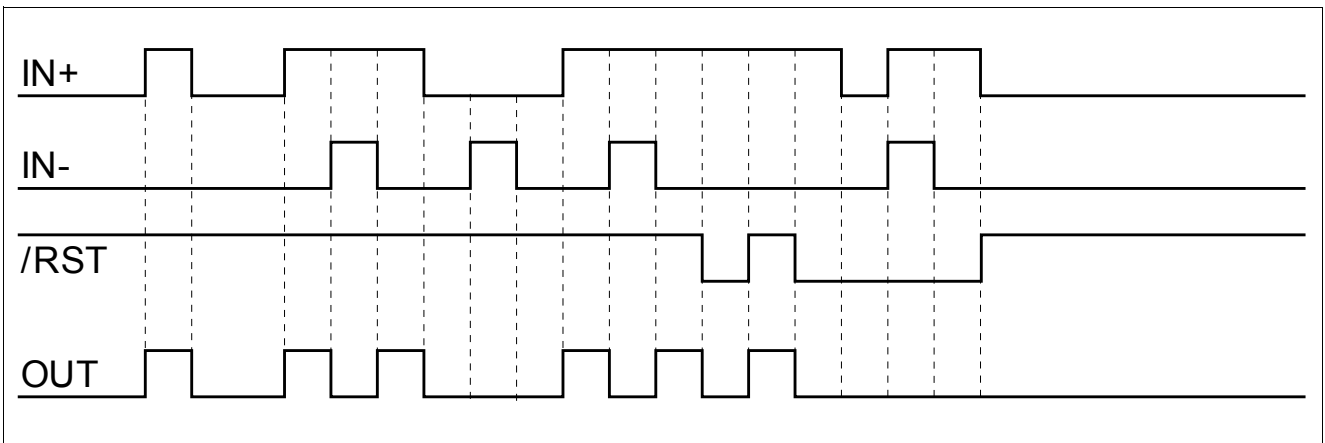

Figure 7 Principle Switching Behavior

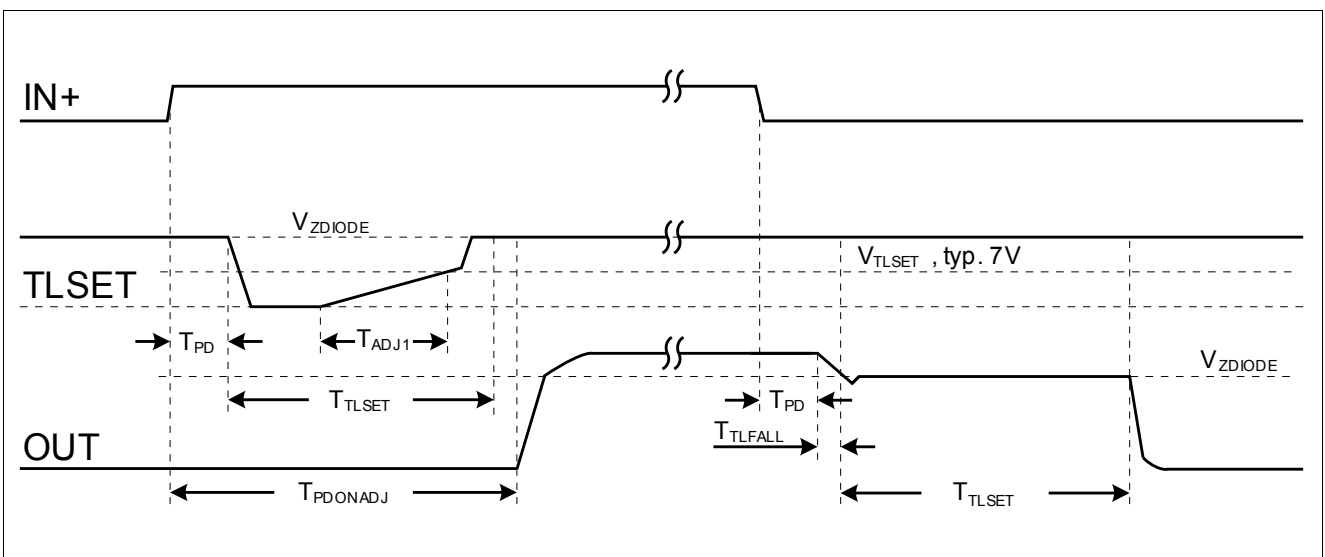

Figure 8 Typical Switching Behavior

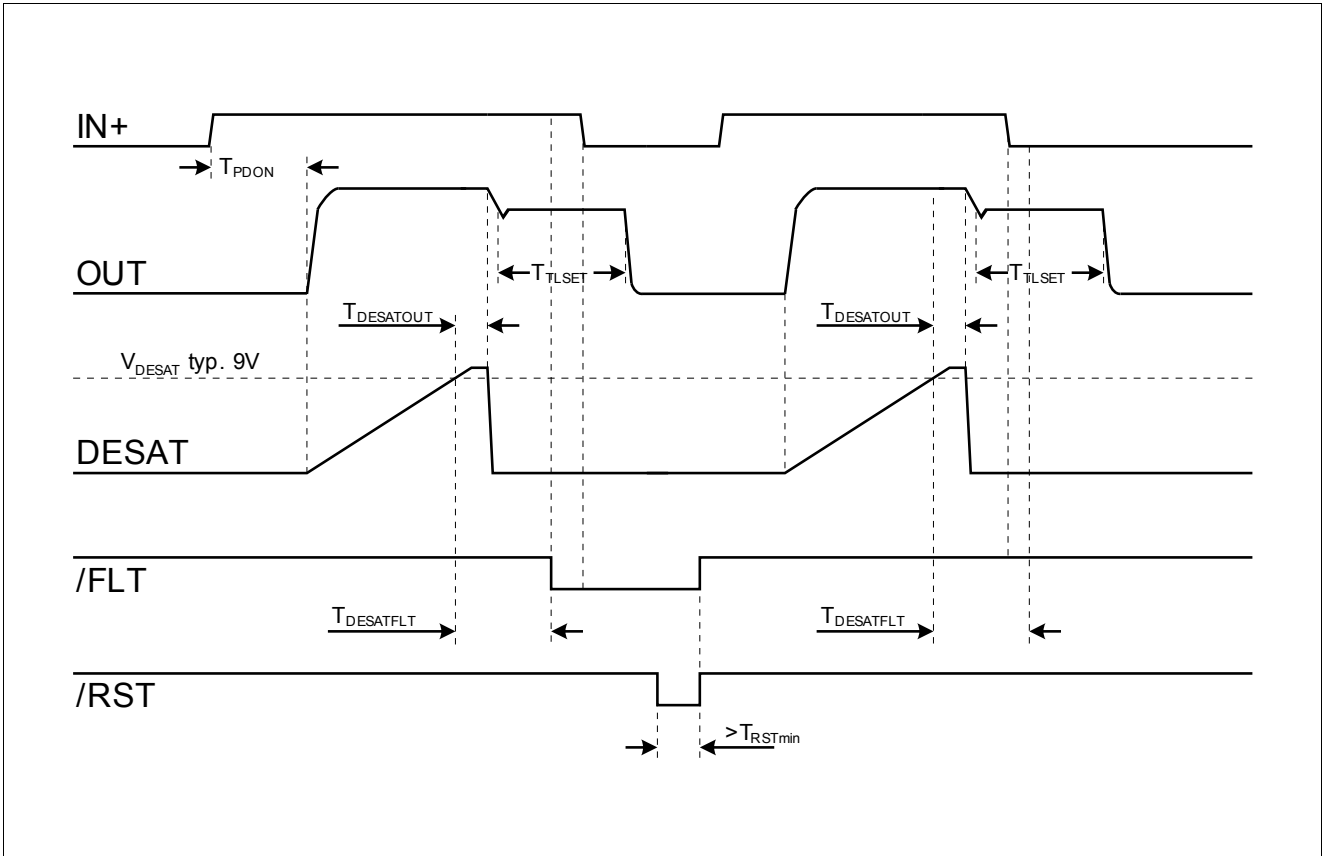

Figure 9 DESAT Switch-Off Behavior

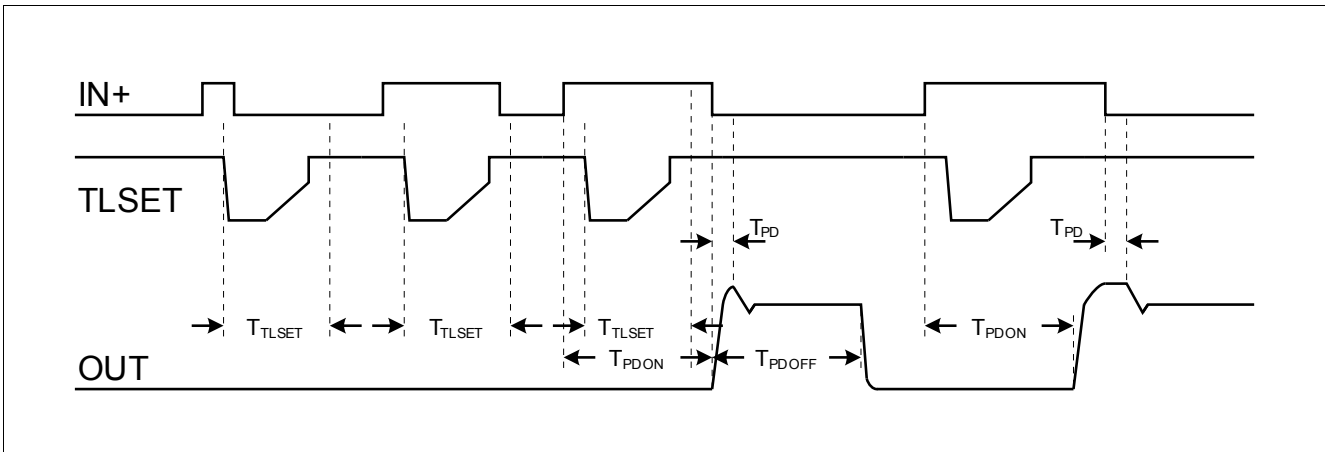

Figure 10 Short Switch ON Pulses

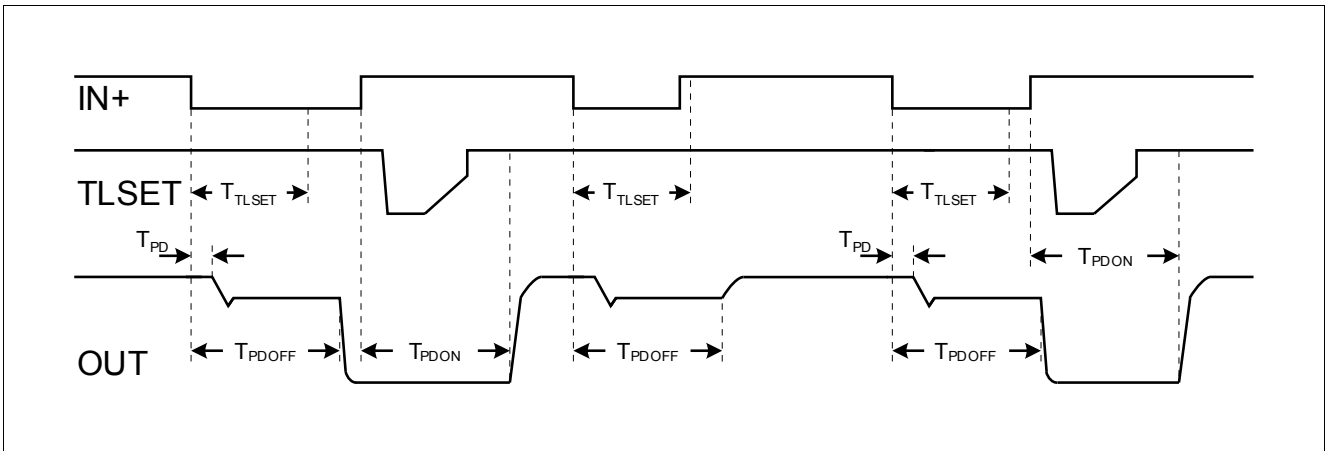

Figure 11 Short Switch OFF Pulses

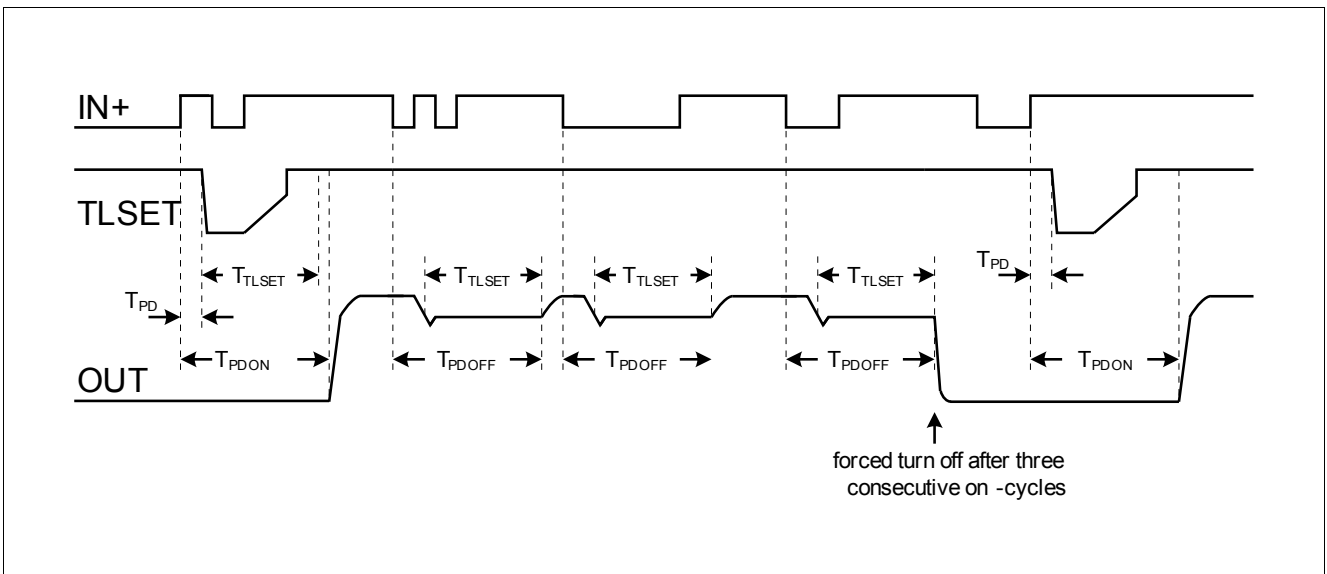

Figure 12 Short Switch OFF Pulses, Ringing Suppression

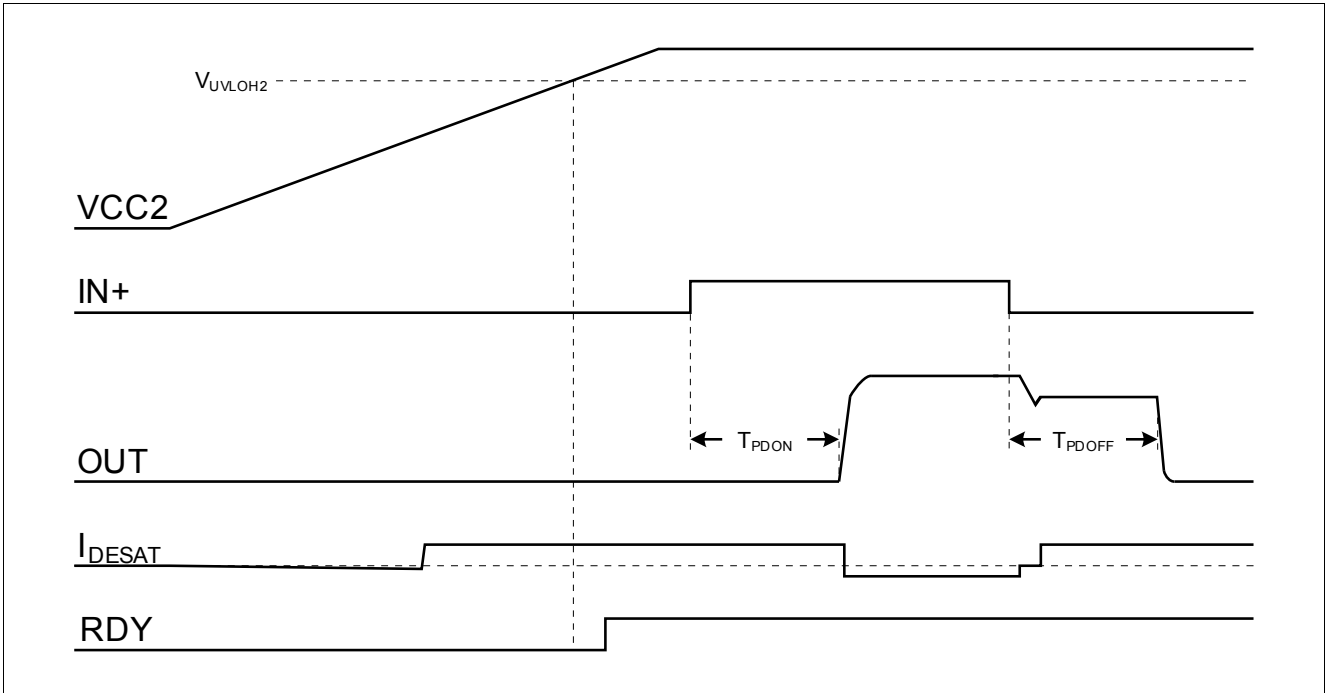

Figure 13 VCC2 Ramp Up

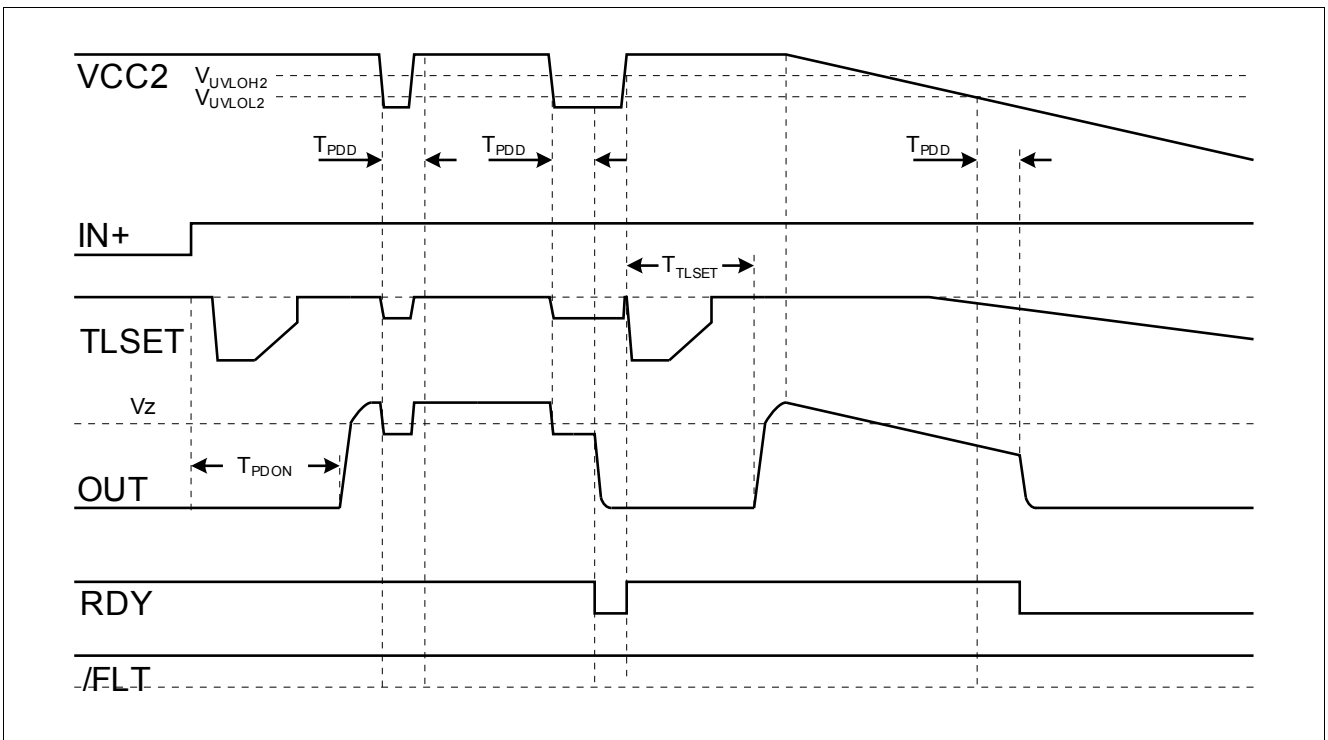

Figure 14 VCC2 Ramp Down and VCC2 Drop

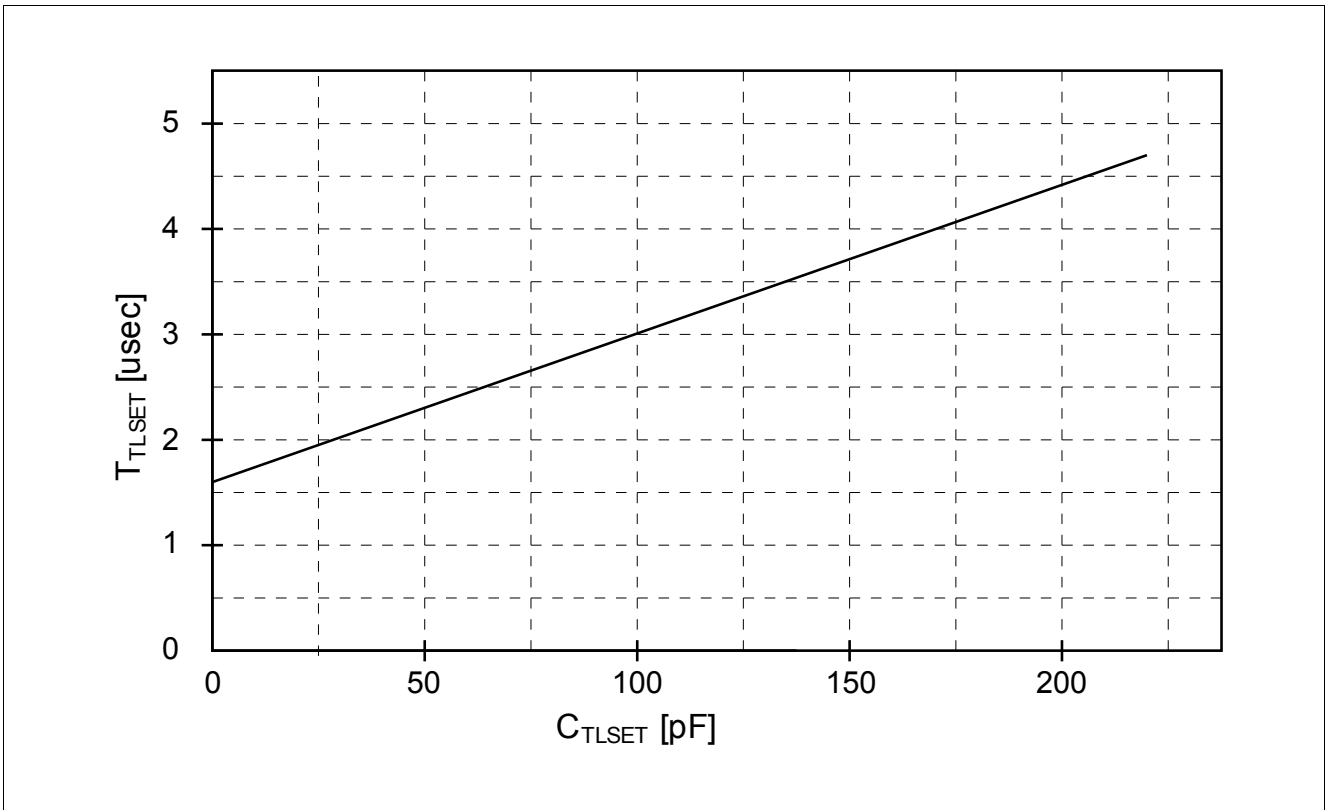

Figure 15 Typical  $T_{TLSET}$  Time over  $C_{TLSET}$  Capacitance

## 8 Package Outlines

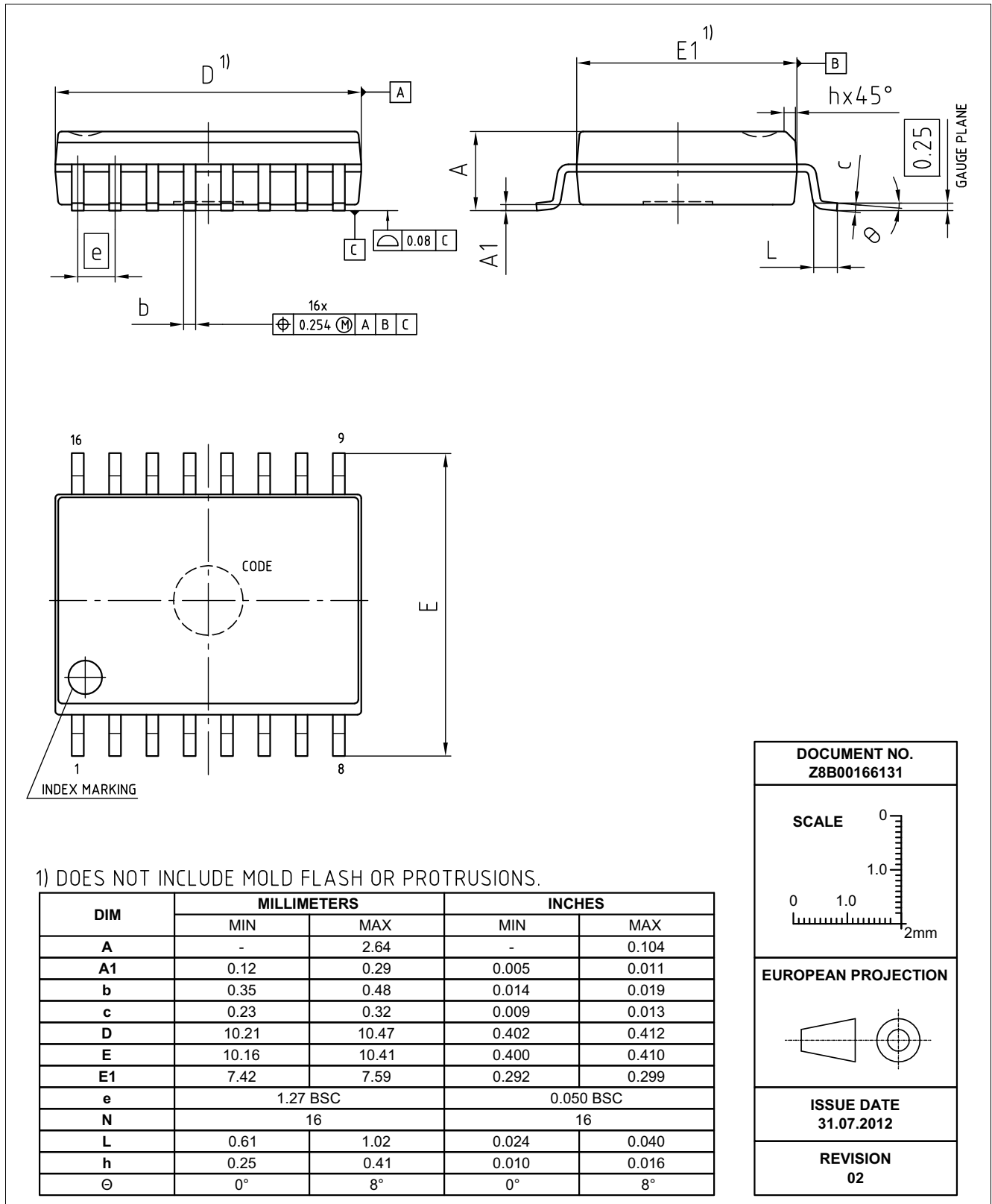

Figure 16 PG-DSO-16-15 (Plastic (Green) Dual Small Outline Package)



## 9 Application Notes

### 9.1 Reference Layout for Thermal Data

The PCB layout shown in [Figure 17](#) represents the reference layout used for the thermal characterisation. Pins 9 and 16 (GND1) and pins 1 and 8 (VEE2) require ground plane connections for achieving maximum power dissipation. The 1ED020112-BT is conceived to dissipate most of the heat generated through this pins.

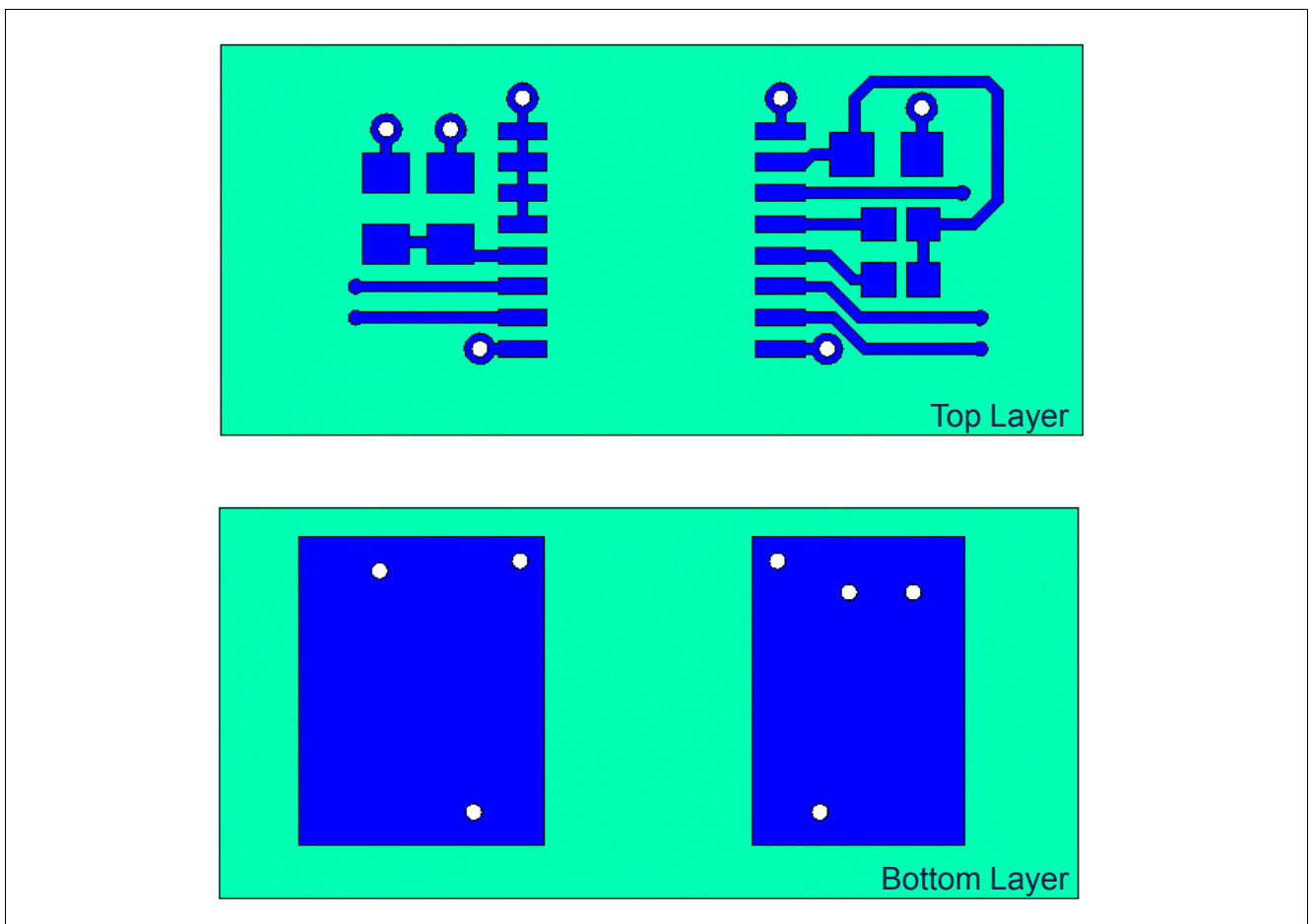

Figure 17 Reference Layout for Thermal Data (Copper thickness 102 µm)

### 9.2 Printed Circuit Board Guidelines

Following factors should be taken into account for an optimum PCB layout.

- Sufficient spacing should be kept between high voltage isolated side and low voltage side circuits.
- The same minimum distance between two adjacent high-side isolated parts of the PCB should be maintained to increase the effective isolation and reduce parasitic coupling.
- In order to ensure low supply ripple and clean switching signals, bypass capacitor trace lengths should be kept as short as possible.
- Lowest trace length for VEE2 to GND2 decoupling could be achieved with capacitor closed to pins 1 and 3.

[www.infineon.com](http://www.infineon.com)

Published by Infineon Technologies AG